

SPECIFICATIONS

| | |
|--|-----------------------|
| Rated thermal input | 8 kW |
| Efficiency | 84 % |
| Smoke flue diameter | 200 mm |
| Min. thrust (under pressure) for rated thermal input | 12 Pa |
| Fuel gas temperature | 257 °C |
| Volume of fuel gas | 6 g/s |
| CO emissions in fuel gas (at 13 % O ₂) | 0,0868 % |
| Dust in the fuel gas (at 13 % O ₂) | 18 mg/Nm ³ |
| Volume of fuel per hour | 2,7 kg/h |
| Fuel | wood (beech logs) |
| Weight | 184 kg |



LIST OF SPARE PARTS

Glass



750 x 468 mm

Carcon stones

1. Front bottom
2. Back bottom
3. Back
4. Right side
5. Left side
6. Deflector
7. Cast iron grid
8. Ash tray

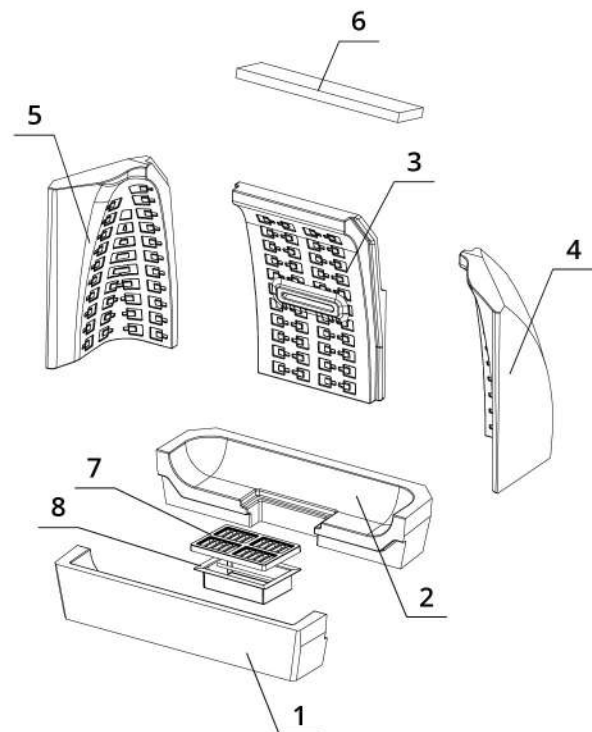

BEF THERM 8

BlmSchV
Stufe 2

15a
B - VG

ČSN EN
13229

TECHNICAL DRAWING

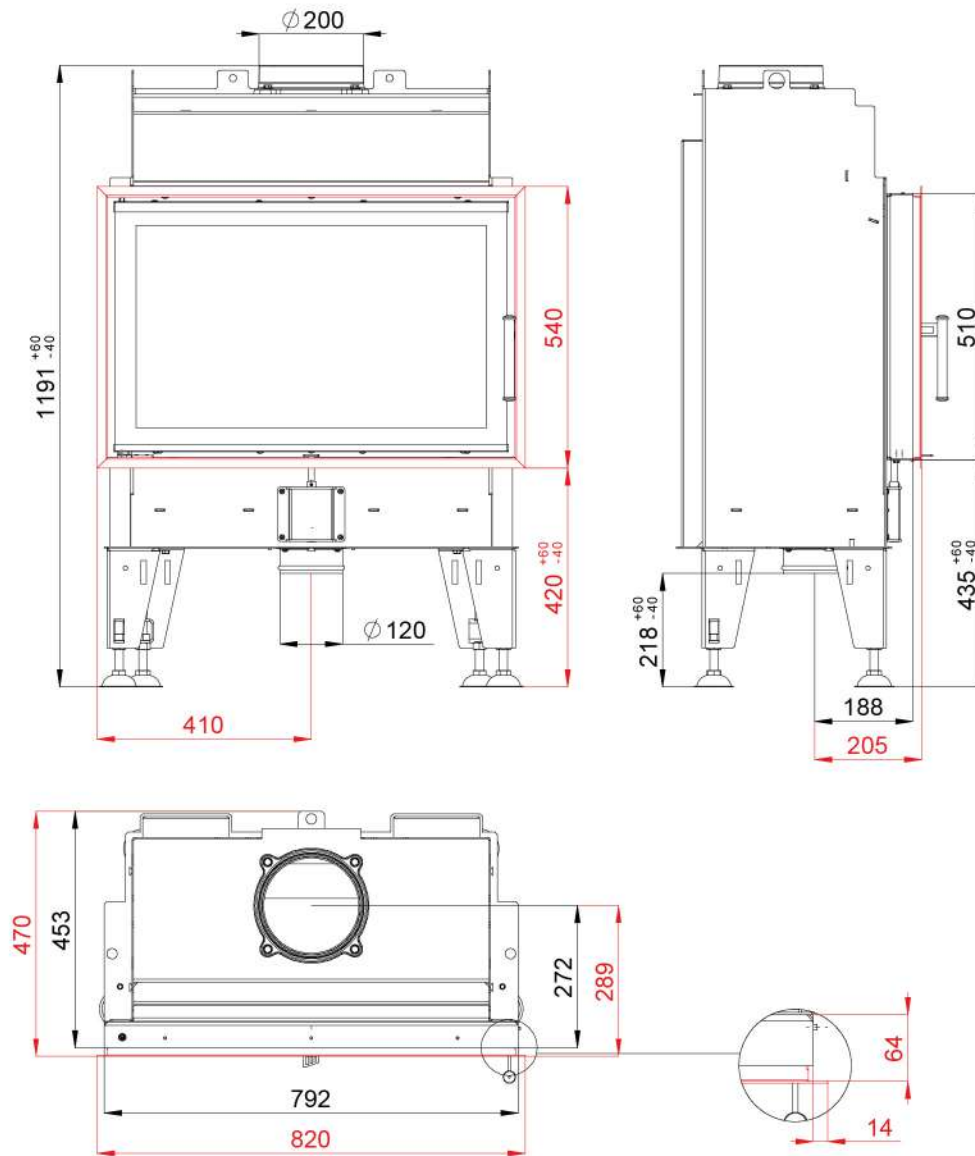

BEF THERM 8

| | | |
|--------------------|-------------|-----------------|
| BImSchV Stufe 2 | 15a B-VG | ČSN EN 13229 |
|--------------------|-------------|-----------------|

www.befhome.com